

# Model 461-57S



# 461-57S “Roll-Out” Diaphragm Regulators

Maximum Inlet Pressure—All Models	Regulator Body Type	461 Body Material	Maximum Working Pressure of Body	Maximum Inlet Pressure
	Screwed End	CAST IRON (ASTM A126-71 Class B)	250 psi	250 psi
	Flanged ANSI 125 lb. FF	CAST IRON (ASTM A126-71 Class B)	175 psi	175 psi
	Flanged ANSI 250 lb. RF	DUCTILE IRON (ASTM A395-71 GR 60-40-18)	575 psi	575 psi
	Flanged ANSI 300 lb. RF	CAST STEEL (ASTM A2 16-70A GR WCB)	720 psi	720 psi
	Flanged ANSI 600 lb. RF	CAST STEEL (ASTM A216-70A GR WCB)	1200 psi	1000 psi

Maximum Pressure Differential and Maximum Inlet Pressure for Various Soft-Seated Valve Materials*	Valve Material	Maximum Pressure Differential	Maximum Inlet Pressure
	Buna-N (black, 50 to 55 duro)	250 psi	575 psig
	Polyurethane (red, 65 to 75 duro)	400 psi	720 psig
	Polyurethane (tan, 85 to 95 duro)	600 psi	1200 psig

\*The differential and inlet pressure given are only to be used as general guidelines. In all cases, pressures must always remain within the ranges specified in Sensus literature. For any given regulator, do not exceed the specified maximum pressures.

The maximum temperature for the above materials is 150° F.

Viton valve material has a maximum temperature rating of 300°F and maximum pressure differential of 250 psi.

Spring Ranges	Outlet Pressure Range	Spring Color	Spring Part Number
	3 to 6 psi	Yellow	091-00-021-05
	5 to 9 psi	Gray	091-00-021-04
	7½ to 15 psi	Blue	091-00-021-03
	12½ to 30 psi	Red	091-00-021-02
	25 to 55 psi	Brown	091-00-021-01
	50 to 75 psi	Black	091-00-021-00
	70 to 100 psi	Brown	091-00-021-01
		White*	091-00-021-08*

\*Inner Spring

Pipe Size	Model 461-57S	Temperature Limits
	Only 2" Available	

### Buried Service

The 461-57S “Roll-Out” Diaphragm Regulator is **not** recommended for buried service.

**Caution:** It is the user’s responsibility to assure that all regulator vents and/or vent lines exhaust to a non-hazardous location away from any potential sources of ignition. Refer to Sensus Bulletin RM-1331 for more detailed information.

# The "Roll-Out" Diaphragm



The Measure of the Future

The heart of the Model 461-57S is the "Roll-Out" diaphragm. The 461-57S is a spring regulator with performance which approximates that of a pilot operated regulator. The "Roll-out" Diaphragm makes this exceptional performance possible because its action reduces "droop" to a minimum ("droop" being fall off in outlet pressure as a spring regulator opens to increase flow.)

The action of the "Roll-Out" diaphragm differs from that of the conventional diaphragm in the manner in which the change in effective area occurs. Where the effective area of a conventional diaphragm would increase as the regulator opens, the "Roll-Out" area decreases. Conversely, where the area of the conventional diaphragm decreases during closing, the "Roll-Out" area increases. The following explanation and the illustrations below show how this affects regular performance.

Spring type regulators are operated by the inter-action between spring and diaphragm. The compressive force of the spring works to open the regulator and is balanced by the opposing force of outlet pressure on the diaphragm which provides the closing force.

As the regulator opens, the compressive force of the spring decreases. However, as this spring force decreases, there must be a corresponding decrease in the opposing force from the diaphragm. For this opposing diaphragm force to decrease,

either the effective area or the outlet pressure must decrease. Herein is the essential difference; with a conventional diaphragm the outlet pressure must decrease, where as with the "Roll-Out" diaphragm it is the effective area that decreases, permitting the outlet pressure to remain constant.

The operation actually is quite simple, yet the action of the "Roll-Out" diaphragm is so effective that "droop" is practically eliminated.

The Model 461-57S provides constant pressure regulation not previously possible in a "pounds to pounds" spring regulator. It approaches pilot performance, and, in addition, offers the further advantages of simplicity, dependability, freedom from freeze-up, and exceptionally fast response.

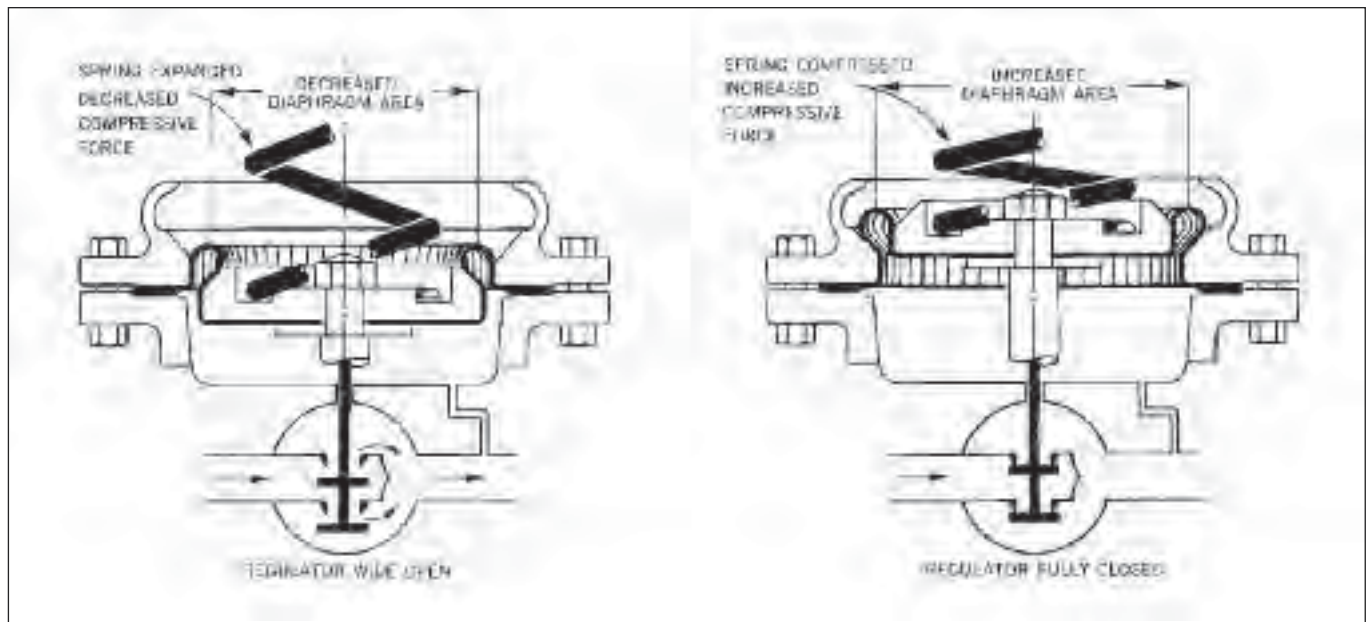
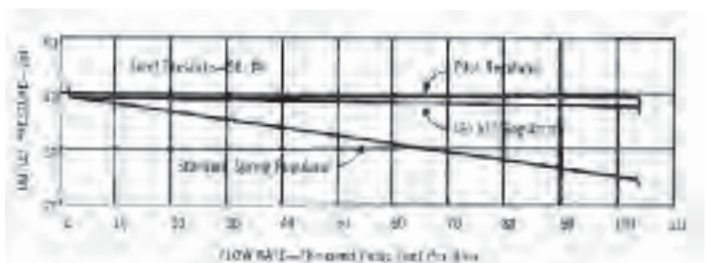

## Other Features

**Simple Design**—dependable regulation—trouble free operation—fast response—no pilot—no pilot freezing—no pilot maintenance.

**Standard Face to Face Dimensions**

**Standardized "461" Bodies & Inner Valve Assemblies—**

easy maintenance—parts are interchangeable with other 461 models (see page 6.)

**Simplified Valve Adjustment**—easy to adjust for tight lock-up—accurate.

**Molded Soft Seats**—Buna -N or Polyurethane—positive tight shut-off—reduces potential of blow out.

**O-Ring Stem Seal**—with removable anti-friction bushing.

**Bushing Guided Inner Valve**—accurate stem alignment and valve seating.

**Side Inspection Plates**—both sides of body.

**Tetraseal Type Body Seals**—eliminate gaskets on upper and lower body openings and side inspection plates.

**Self-Aligning Spring Adjustment**—color coded springs.

**Removable Seats (Orifices)**—easily changed with standard 1½" hex deep socket wrench.

## 461-57S

### “Roll-Out” Diaphragm Regulators

#### Intermediate Capacity

for

- Gas Distribution Systems
- District Regulator Sets
- City Gate Stations
- Town Border Stations
- Monitoring
- Industrial Applications
- Industrial Burners
- Furnaces, Ovens, Boilers

#### Inlet Pressures and Capacities

See page 5

#### Valve Travel Indicator

#### Anti-Friction Bushing

#### Heavy-Duty Construction

Weather-proof  
Watertight  
For Indoor  
or Outdoor  
Installations

#### Outlet Pressure Range

**3 to 100 psi**

Note: For outlets up to 250 psi, see Model 461-X57. (Bulletin R-1332)

For outlets below 3 psi, see Model 461-S. (Bulletin R-1330)

#### “Roll-Out” Diaphragm (Patented)

#### Balanced Valve Double Seat (shown) or Single Seat See page 6

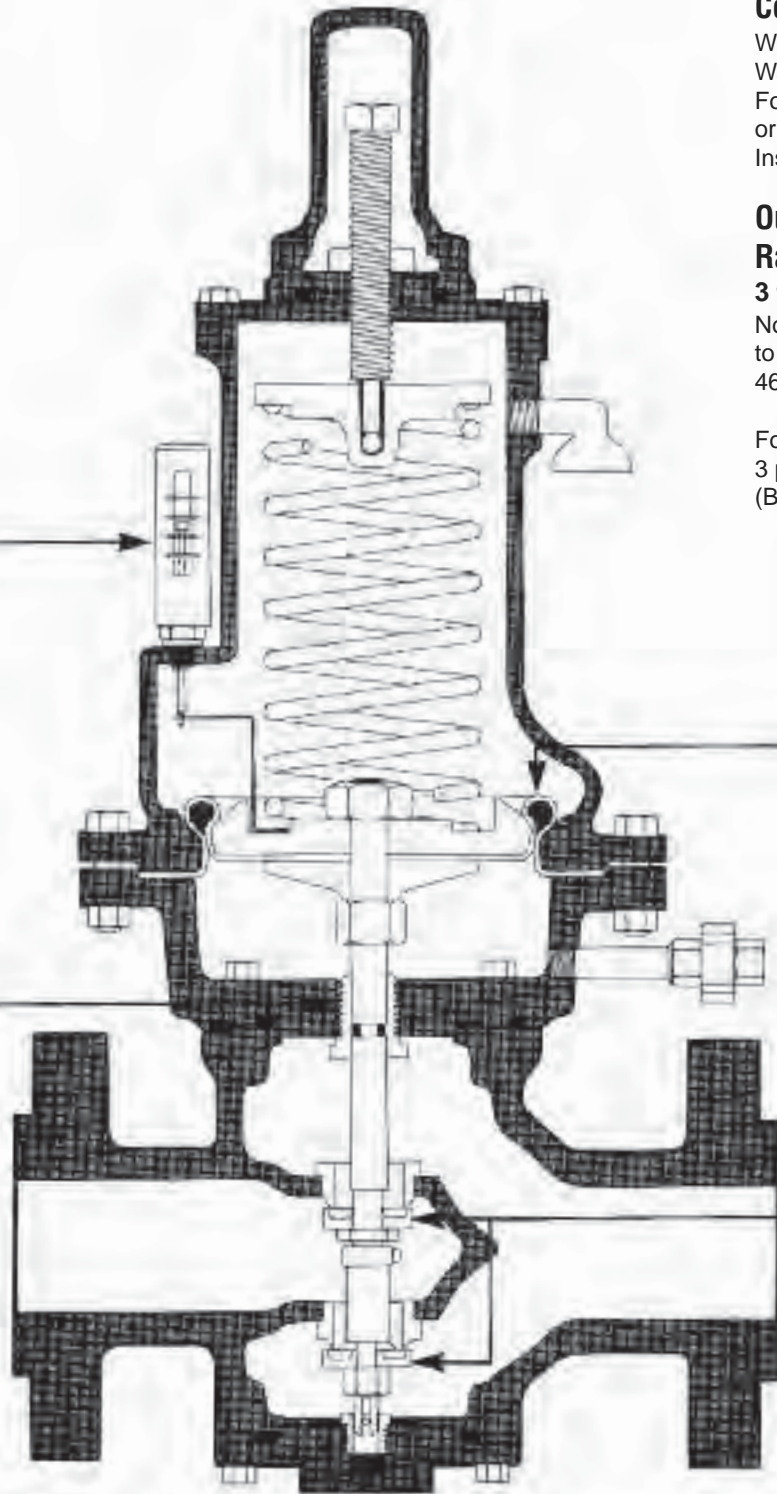

# 461-57S "Roll-Out" Diaphragm Capacity Tables



The Measure of the Future

## Capacity in 1000 SCFH of Natural Gas (0.6 Specific Gravity–14.65 psia–60°F)

Inlet Pressure psi	Outlet Pressure psi	Double Seat Balanced		Single Seat Balanced	
		1" Valve	1/4" Valve	1" Valve	1/4" Valve
4	3	8.4	4.2	5.4	2.7
5	3	11.8	5.9	7.6	3.8
	4	8.6	4.3	5.6	2.8
6	3	14.4	7.2	9.3	4.6
	4	12.2	6.1	7.9	3.9
	5	8.8	4.4	5.7	2.8
8	3	18.6	9.6	12.1	6.0
	4	17.2	8.6	11.1	5.6
	5	15.2	7.6	9.8	4.9
	6	12.8	6.4	8.3	4.1
10	3	22.2	11.1	14.4	7.2
	4	21.0	10.5	13.6	6.8
	5	19.8	9.9	12.8	6.4
	6	18.0	9.0	11.7	5.8
12	8	13.4	6.7	8.7	4.3
	3	25.2	12.6	16.3	8.2
	4	24.4	12.2	15.8	7.9
	5	23.4	11.7	15.2	7.6
	6	22.2	11.1	14.4	7.2
15	8	19.0	9.5	12.3	6.1
	10	14.0	7.0	9.1	4.5
	3	29.0	14.5	18.8	9.4
	4	28.6	14.3	18.6	9.3
	5	28.0	14.0	18.2	9.1
	6	27.2	13.6	17.6	8.8
20	8	25.0	12.5	16.2	8.1
	10	22.2	11.1	14.4	7.2
	12	17.8	8.9	11.5	5.7
	3	34.6	17.3	22.5	11.2
	4	34.4	17.2	22.3	11.1
	6	34.0	17.0	22.1	11.0
	8	32.8	16.4	21.3	10.6
25	10	31.4	15.7	20.4	10.2
	12	29.2	14.6	18.9	9.5
	15	24.2	12.1	15.7	7.8
	6 & less	39.6	19.8	25.7	12.8
	8	39.2	19.6	25.4	12.7
	10	38.4	19.2	24.9	12.4
30	12	37.2	18.6	24.1	12.1
	15	34.4	17.2	22.3	11.1
	20	26.2	13.1	17.0	8.5
	9 & less	44.4	22.2	28.8	14.4
	10	44.2	22.1	28.7	14.3
	12	43.8	21.9	28.4	14.2
40	15	42.0	21.0	27.3	13.6
	20	37.2	18.6	24.1	12.1
	25	28.0	14.0	18.2	9.1
	14 & less	54.4	27.2	35.3	17.6
	20	52.6	26.3	34.2	17.1
50	25	48.6	24.3	31.6	15.8
	30	42.2	21.1	27.4	13.7
	35	31.4	15.7	20.4	10.2
	20 & less	64.4	32.2	41.8	20.9
50	25	62.8	34.1	40.8	20.4
	30	59.6	29.8	38.7	19.3
	35	54.4	27.2	35.3	17.6

Inlet Pressure psi	Outlet Pressure psi	Double Seat Balanced		Single Seat Balanced	
		1" Valve	1/4" Valve	1" Valve	1/4" Valve
50	40	46.6	23.3	30.3	15.1
	45	34.4	17.2	22.3	11.1
60	25 & less	74.4	37.2	48.3	24.1
	30	73.2	36.6	47.5	23.8
	40	66.0	33.0	42.9	21.4
	50	50.8	25.4	33.0	16.5
80	35 & less	94.2	47.1	61.2	30.6
	40	93.2	46.6	60.5	30.3
	50	87.8	43.9	57.0	28.5
	60	77.2	38.6	50.1	25.1
	70	58.0	29.0	37.7	18.8
100	45 & less	114	57.2	74.3	37.1
	50	113	56.8	73.8	36.9
	60	109	54.6	70.9	35.5
	70	100	50.3	65.4	32.7
	80	86.8	43.4	56.4	28.2
125	60 & less	139	69.6	90.4	45.2
	70	136	68.2	88.6	44.3
	80	130	65.2	84.7	42.3
	100	107	53.5	69.5	34.7
150	73 & less	164	82.0	106	53.3
	80	162	81.3	105	52.8
	100	151	75.7	98.4	49.2
175	85 & less	189	94.8	123	61.6
	100	185	92.7	120	60.2
200		214	107	139	69.6
250		264	132	171	85.9
300		314	157	204	102
350	100 & less	364	182	236	118
400		414	207	269	134
500		514	257	334	167
600		614	307	399	199
800		814	407	529	264
1000		1014	507	659	329
"K" FACTORS			2000	1000	1300

**Note:** The above performance data is based on normal testing at 70°F flowing temperature. Changes in performance can occur at extreme low flowing temperatures.

# Type 461 Balanced Valves

## Fully Interchangeable Valve Assemblies

Valve assemblies can be interchanged with the regulator in place in the line.

Use the 1/2" Single Seat initially for small loads. Then in the future, as loads grow, change only the Valve Assembly, up to 1" Double Seat for maximum capacity.

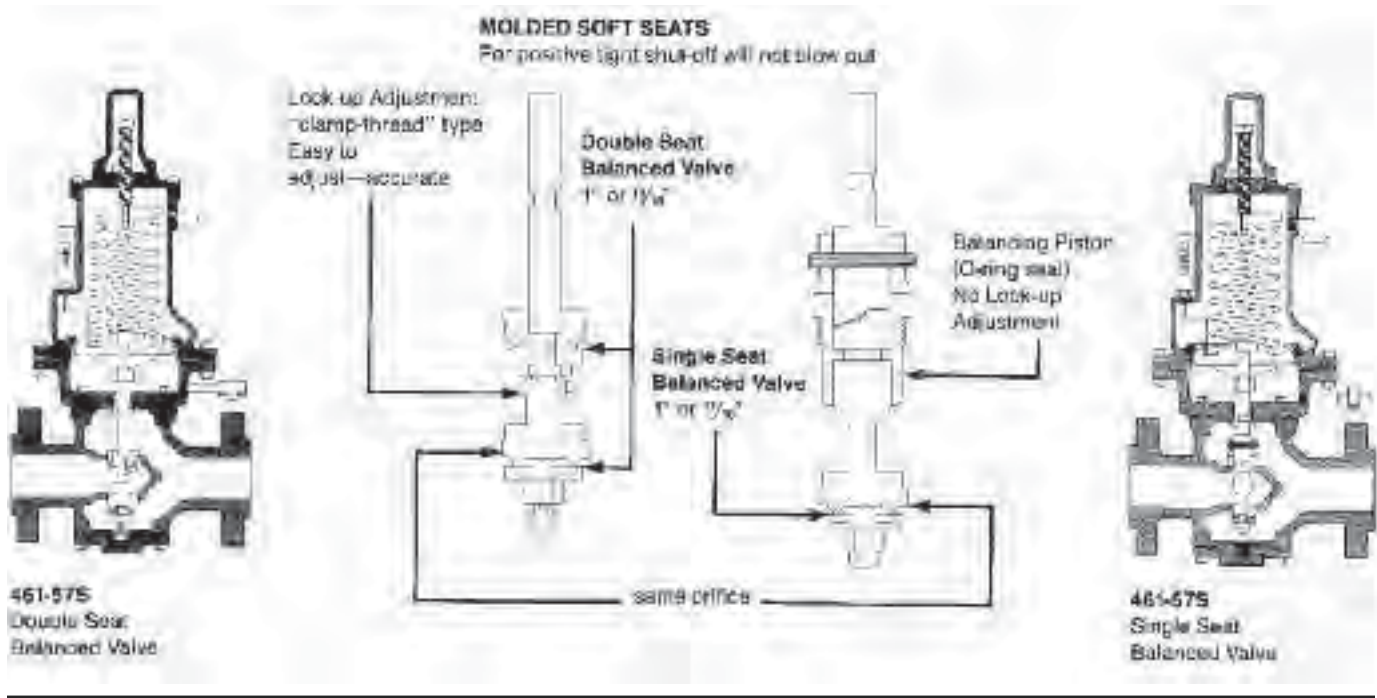

## The 461 Family of Regulators

Other Models Which Use Type 461 Balanced Valves

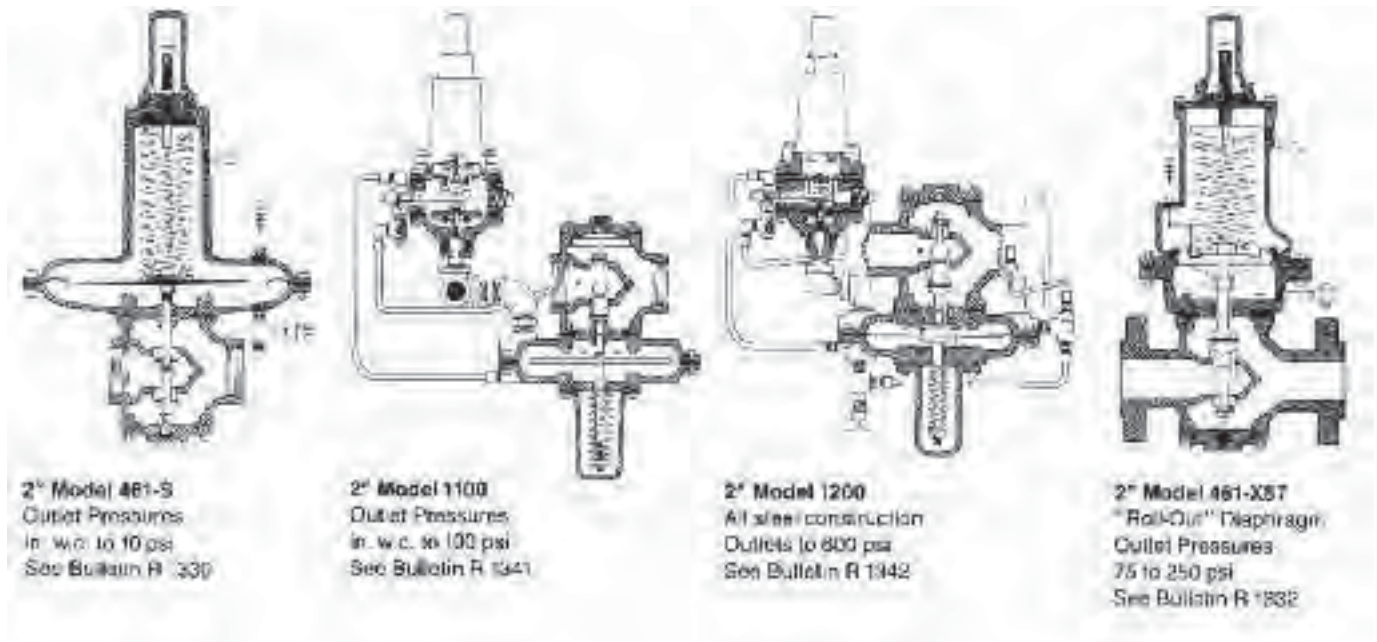

## Maximum Emergency Pressures

The maximum pressure the regulator inlet may be subjected to under abnormal conditions without causing damage to the regulator is:

Cast Iron Body, Screwed End .....	275 psi
Cast Iron, Flanged ANSI 125 lb.....	200 psi
Ductile Iron, Flanged ANSI 250 lb.....	630 psi
Cast Steel, Flanged ANSI 300 lb.....	800 psi
Cast Steel, Flanged ANSI 600 lb.....	1100 psi

The maximum pressure the outlet may be subjected to without causing damage to the internal parts of the regulator is:

All 461-57S..... set point +25 psi

Set-point is defined as the outlet pressure a regulator is adjusted to deliver.

If any of the above pressure limits are exceeded, the regulator must be taken out of service and inspected. Damaged or otherwise unsatisfactory parts must be repaired or replaced.

The maximum pressure that can be safely contained by the diaphragm case is:

All 461-57S ..... 175 psi

Safely contained means no leakage as well as no bursting.

**Before using any of the above data, make sure this entire section is clearly understood.**

## Overpressurization Protection

Protect the downstream piping system and the regulator's low pressure chambers against overpressurization due to possible regulator malfunction or failure to

achieve positive lockup. The allowable outlet pressure is the lowest of the maximum pressures permitted by federal codes, state codes, Bulletin RDS-1498 or other applicable standards. The method of protection can be a relief valve, monitor regulator, shut-off device or similar mechanism.

## Capacities at Other Pressures

Capacity for pressure reductions not listed in the table can be calculated with the following formulae:

$$1. Q = K \sqrt{P_0(P_1 - P_0)} \dots \dots \dots \text{(for } \frac{P_1}{P_0} \text{ less than 1.894)}$$

$$2. Q = \frac{KP_1}{2} \dots \dots \dots \text{(for } \frac{P_1}{P_0} \text{ greater than 1.894)}$$

Q = maximum capacity of the regulator (in SCFH of 0.6 specific gravity natural gas).

K = the "K" factor, the regulator constant (from the table)

P<sub>1</sub> = **absolute** inlet pressure (psia).

P<sub>0</sub> = **absolute** outlet pressure (psia).

Use formula 1 when  $\frac{P_1}{P_0}$  is less than 1.894.

Use formula 2. when  $\frac{P_1}{P_0}$  is greater than 1.894.

## Other Gases

Model 461-57S Regulators are mainly used on natural gas. However they perform equally as well on LP gas, nitrogen, dry CO<sub>2</sub>, air and others.

OTHER GASES	CORRECTION FACTOR
Air (Specific Gravity 1.0)	0.77
Propane (Specific Gravity 1.53)	0.63
1350 BTU Propane-Air Mix (1.20)	0.71
Nitrogen (Specific Gravity 0.97)	0.79
Dry Carbon Dioxide (Specific Gravity 1.52)	0.63
For other noncorrosive gases: CORRECTION FACTOR =	$\sqrt{\frac{0.6}{\text{Specific Gravity of the Gas}}}$

For use with other gases not listed above, please contact your Sensus representative or Industrial Distributor for recommendations.

# General Information

## Materials of Construction

Diaphragm Housing, Spring Cage	Cast Iron (ASTM) A126-71 Class B)
Housing Cover (Spring Cage Cap)	Ductile Iron (ASTM A395-71 gr 60-40-18)
Lower Diaphragm Plate	Cast Iron
Upper Diaphragm Plate	Die Cast Aluminum
Diaphragm	Buna-N with Dacron Reinforcement
Diaphragm Stud	Stainless Steel
Removable Outlet Orifices	Brass or Stainless Steel
Valve Stems	Brass or Stainless Steel
Stem Bushing	Anti-Friction Bushing
Valve Seat Material	Buna-N, Viton, Polyurethane or Nylon molded in holder
Holder for Molded Valve Stainless Steel for Nylon Seat	Steel for Soft Seat
Valve Retainer	Brass or Stainless Steel
Bodies	see table on Page 3

## Metrification

Use the following for Metric conversions:

Std. metres <sup>3</sup> /hr. x 35.31 = std. ft. <sup>3</sup> /hr. (SCFH) std. ft. <sup>3</sup> /hr. (SCFH) x 0.0283 = std. metres <sup>3</sup> /hr.
kilograms/centimeter <sup>2</sup> (kg/cm <sup>2</sup> ) x 14.22 = psig psig x 0.0703 = kilograms/centimeter <sup>2</sup> (kg/cm <sup>2</sup> )
kilopascals (kPa) x 0.145 = psig psig x 6.90 = kilopascals (kPa)
bars x 14.50 = psig psig x 0.069 = bars
millimeters water (mm H <sub>2</sub> O) x .394 = in. w.c. in. w.c. x 25.4 = millimeters water (mm H <sub>2</sub> O)
millimeters mercury (mm Hg) x 0.535 = in. w.c. in. w.c. x 1.868 = millimeters mercury (mm Hg)

## Monitoring

The Model 461-57S is also excellent for use as a monitor; a stand-by regulator mounted in series which assumes control if a failure in the operating regulator permits the outlet pressure to rise above its set point.

The 461-57S has a fast rate of response and, therefore, will take control quickly in case of an emergency. It requires no changes or modifications when used for monitoring. Its simple design and rugged construction make it an exceptionally dependable regulator, and its control accuracy and freedom from "droop" means that it will provide excellent regulation if an emergency calls it into operation.

Two monitor set arrangements are shown in the sketches below. The first shows a set in which the operating regulator and the monitor are both Model 461-57S. This makes an unusually neat and compact installation.

The 461-57S is also used for monitoring other types of regulators. This is shown in the second sketch. It is excellent for monitoring pilot operated regulators.

Both sketches show the monitor in the downstream position. When installed this way, the 461-57S is usually set for an outlet pressure 2 to 4 psi higher than the operating regulator and thus is wide open during normal operation.

The monitor can also be located upstream, and with this arrangement the 461-57S is usually set for an outlet somewhat higher than the above.

Shutoff and bypass valving varies with individual practices and requirements. In general, however, the sketch on page 9 "Typical Installation" can be used as a guide for the arrangement of these valves.

When identical 461-57S regulators are used for both the operating regulator and the monitor, the **total maximum capacity** through both may be figured as 70 percent of the capacity of one of them alone. This applies with the monitor located either downstream or upstream.

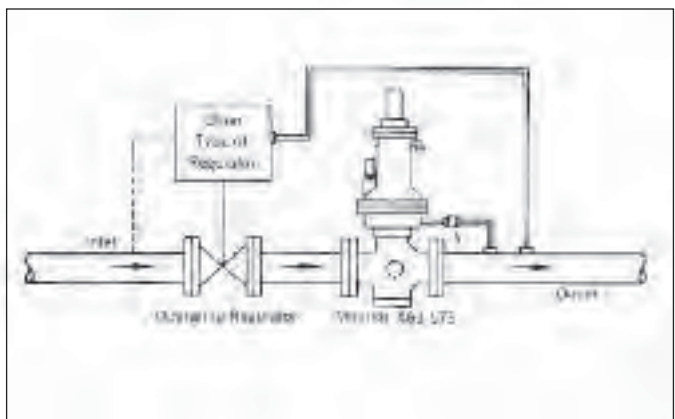
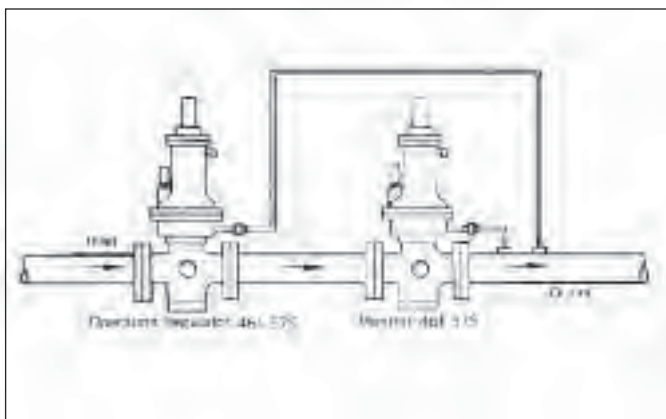

**Periodic Inspection:** Regulators are pressure control devices with numerous moving parts subject to wear that is dependent upon particular operating conditions. To assure continuous satisfactory operation, a periodic inspection schedule must be adhered to with the frequency of inspection determined by the severity of service and applicable laws and regulations. **See bulletin RM-1331 for field service instructions.**



The simple and compact design of the Model 461-57S makes it an easy regulator to install. The sketch below shows a typical arrangement.

The regulator will work to deliver the pressure, for which it is adjusted, at that point in the downstream system where the **downstream control line connection** is made.

As a general rule, it should be at least 8 pipe diameters downstream from the regulators and should be located in as straight a run of pipe as possible. Where outlet piping increases in size near the regulator, it is preferable to connect into the larger diameter portion. The connection itself must be smooth and clean, free of rough edges, wilding icicles, etc.

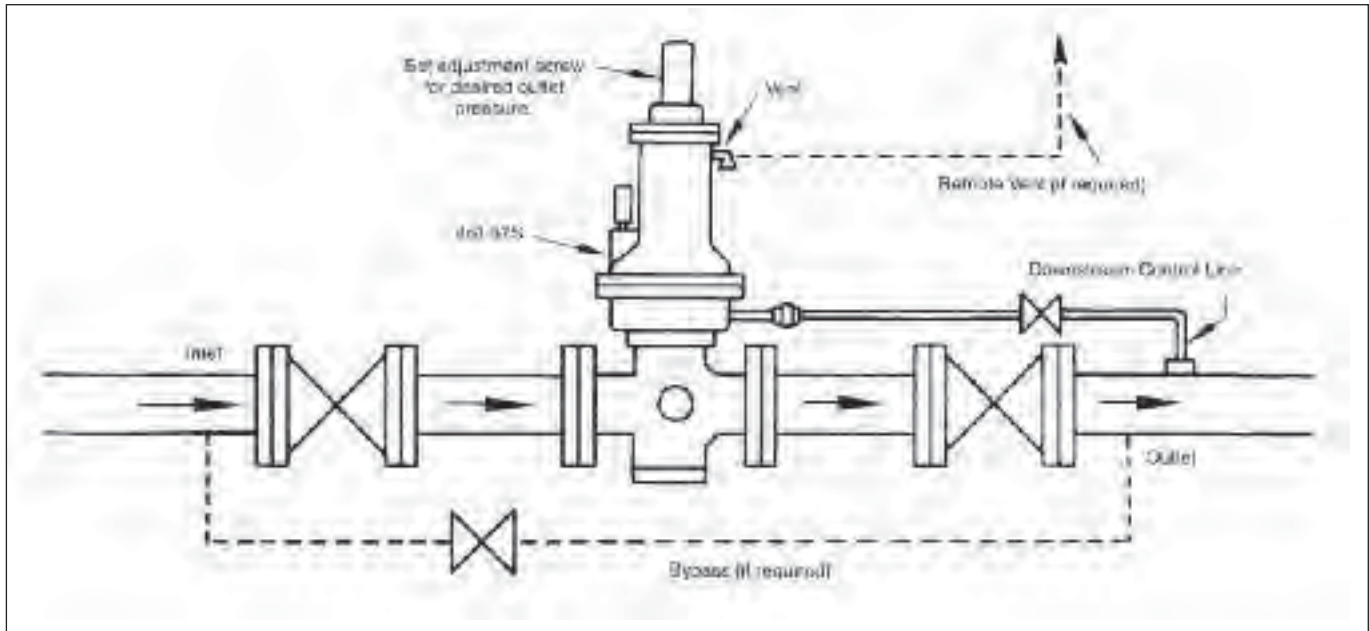

## How to Order

Specify:

- |   |  |   |
|---|--|---|
| <ol style="list-style-type: none"> <li>1. 2" Model 461-57S.</li> <li>2. Piping connections and body material (see table on Page 2)</li> <li>3. Outlet pressure and/or spring (see table on Page 3)</li> </ol> | <ol style="list-style-type: none"> <li>4. Inlet pressure (maximum and minimum, if available)</li> <li>5. Capacity required (SCFH)</li> <li>6. Kind of gas (natural gas, propane, etc.)</li> <li>7. Trim (standard or stainless steel)</li> </ol> | <ol style="list-style-type: none"> <li>8. Valve size (1" or 1 1/8")</li> <li>9. Double seat or single seat (see Page 6)—if not specified, double seat will be furnished.</li> </ol> |
|---|--|---|

**Caution:** Turn gas on slowly. If an outlet stop valve is used, it should be opened first. Do not overload the diaphragm with a sudden surge of inlet pressure. Monitor the outlet pressure during start-up to prevent an outlet pressure overload. **Refer to RM-1331 for more detailed start-up procedures.**

# Dimensions

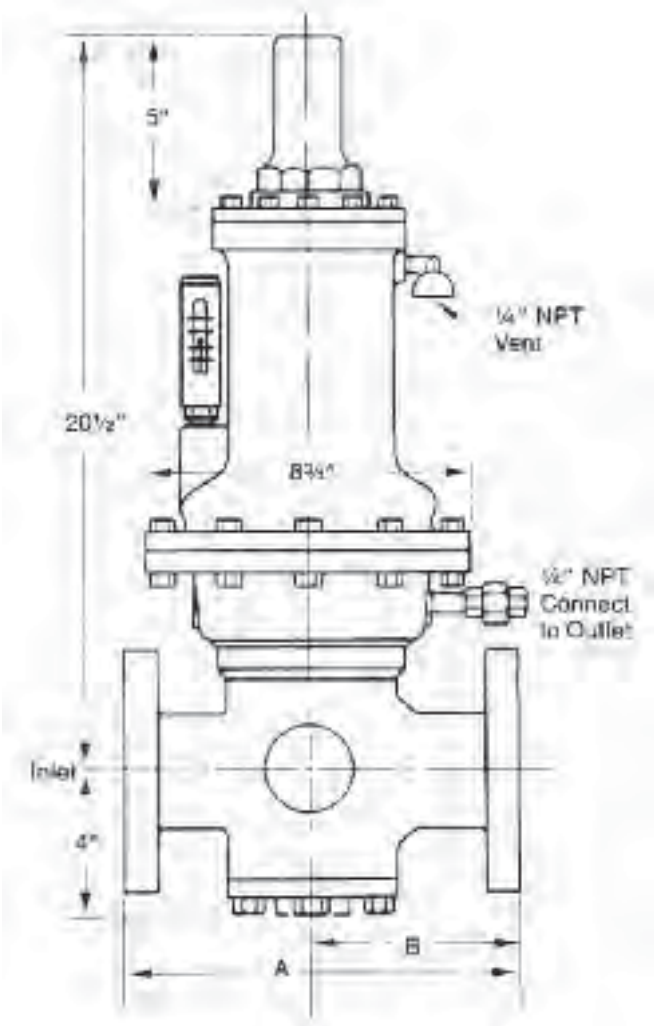

Regulator Body Type	A	B	Shipping Weight Lbs.
Screwed	6 1/2	3 1/4	70
Flanged ANSI 125 lb.	10	5 1/4	80
Flanged ANSI 250 lb.	10 1/2	5 1/2	85
Flanged ANSI 300 lb.	10 1/2	5	88
Flanged ANSI 600 lb.	11 1/4	6	90

# Other Sensus Gas Pressure Regulators



The Measure of the Future

Sensus produces a broad product line of Gas Pressure Regulators which are widely used throughout the natural gas industry. These regulators are also suitable for non-corrosive industrial gas applications such as propane, butane, air,

nitrogen, dry CO<sub>2</sub>, etc. For additional detailed information on a particular model, please request the indicated bulletin from Sensus customer service, or visit our web product catalog at [www.sensus.com/gas](http://www.sensus.com/gas)

## Multi-Purpose Service Regulators

Models 496, 61R2, 143-80  
Bulletin: TD-1301, TD-1307, TD-1308  
1/2", 3/4", 1", and 1 1/4" pipe size  
Inlet pressures . . . . .to 125 psi  
Outlet pressures . . . . .3/2" w.c. to 6 psi  
Capacity to 2250 CFH  
Available with straight through body.  
Also available: internal relief valve and low pressure cut-off.

## Industrial Service Regulators

Models 243-8, 234-12, 243-8HP  
Bulletin: R-1306  
1 1/4", 1 1/2", and 2" pipe size  
Inlet pressures . . . . .to 125 psi  
Outlet pressures . . . . .3/2" w.c. to 10 psi  
Capacity to 25,000 CFH  
Also available: internal relief valve, low pressure cut-off external control line, back pressure regulator, relief valve, vacuum regulator and vacuum breaker.

## Industrial Field Regulators

For intermediate to high pressure applications. Ideal on pipeline taps servicing plants and buildings. Appropriate for double stage reduction ahead of service regulators, and for high pressure burners and compressed air systems.

Model 046  
Bulletin: R-1312  
3/4", 1", and 1 1/4" pipe size  
Inlet pressures . . . . .to 1000 psi  
Outlet pressures . . . . .3 to 200 psi  
Capacity to 40,000 SCFH  
Monitor and pressure loaded version, and internal relief valve also available.

Model 141A  
Bulletin: R-1311  
2" pipe size  
Inlet pressures . . . . .to 1500 psi  
Outlet pressures . . . . .5 to 400 psi  
Capacity to 55,000 SCFH

## Pilot Loaded Regulators

For intermediate and high-pressure applications requiring precise pressure reduction with minimal droop. Ideal for standard and high capacity flows on burners, driers, dehydrators and compressor line. Appropriate for fixed factor billing.

Models 243-RPC  
Bulletin: R-1343  
1 1/4", 1 1/2" and 2" pipe size  
Inlet pressures . . . . .to 150 psi  
Outlet pressures . . . . .3/2" w.c. to 35 psi  
Capacity to 76,000 SCFH

Model 1100  
Bulletin: R-1341  
2" pipe size (screwed or flanged)  
Inlet pressures . . . . .to 400 psi  
Outlet pressures . . . . .3/2" w.c. to 100 psi  
Capacity to 414,000 SCFH

Model 1200  
Bulletin: R-1342  
2" pipe size (flanged)  
Inlet pressures . . . . .to 1200 psi  
Outlet pressures . . . . .20 to 600 psi  
Capacity to 789,000 SCFH

All products purchased and services performed are subject to Sensus' terms of sale, available at either; <http://na.sensus.com/TC/TermsConditions.pdf> or 1-800-METER-IT. Sensus reserves the right to modify these terms and conditions in its own discretion without notice to the customer.

This document is for informational purposes only, and SENSUS MAKES NO EXPRESS WARRANTIES IN THIS DOCUMENT. FURTHERMORE, THERE ARE NO IMPLIED WARRANTIES, INCLUDING WITHOUT LIMITATION, WARRANTIES AS TO FITNESS FOR A PARTICULAR PURPOSE AND MERCHANTABILITY. ANY USE OF THE PRODUCTS THAT IS NOT SPECIFICALLY PERMITTED HEREIN IS PROHIBITED.

Sensus also produces Industrial and Combustion Regulators; High Pressure, High Capacity Regulators; and Safety Relief Valves. Detailed information available upon request.



[www.sensus.com/gas](http://www.sensus.com/gas)

805 Liberty Boulevard

DuBois, PA 15801

800-375-8875

Fax: (814) 375-8460