

# Model 143-80 Service Regulator

## Installation and Maintenance Instructions

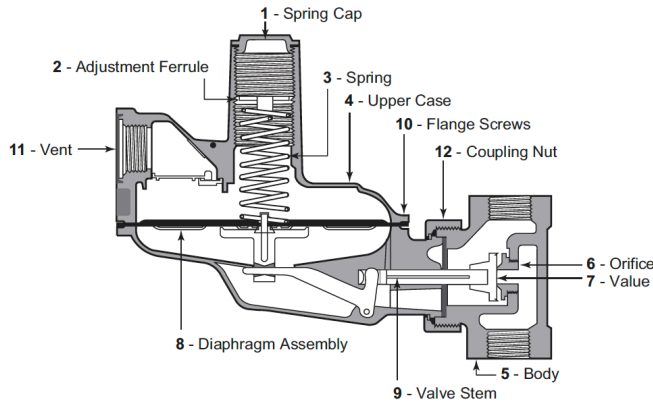

## Warning



Only qualified personnel should install or service a regulator. Regulators should be installed, operated, and maintained in accordance with applicable codes and regulations, and Utility Solutions Group instructions.

If the regulator vents fluid or a leak develops in the system, it indicates that service is required. Failure to take the regulator out of service immediately may create a hazardous condition. Personal injury, equipment damage, or leakage due to escaping fluid or bursting of pressure-containing parts may result if this regulator is over pressured or is installed where service conditions could exceed published specification limits, or where conditions exceed any ratings of the adjacent piping or piping connections.

To avoid such injury or damage, provide pressure-relieving or pressure-limiting devices (as required by the appropriate code, regulation, or standard) to prevent service conditions from exceeding limits.

Additionally, physical damage to the regulator could result in personal injury and property damage due to escaping fluid. To avoid such injury and damage, install the regulator in safe location.

## Caution



Do not overload the diaphragm with a sudden surge of inlet pressure. Turn the gas on very slowly. If an outlet stop is used, it should be opened first. Monitor the outlet pressure during start-up to prevent an outlet pressure overload.

in the vent side of the regulator diaphragm. If required, the upper diaphragm case (4) may be rotated by removing the upper-to-lower case flange screws (10) and rotating the upper diaphragm case to the desired position. Reinstall the diaphragm flange screws and tighten to hold the diaphragm case in position, ensuring proper seal and no leaks.

## Installation & Start-Up

The Model 143-80 is a general purpose pressure regulator used for natural gas, air, dry CO<sub>2</sub>, propane, butane, nitrogen, and other gases. It can be used for gas services to homes, commercial establishments and small industries as well as burners, unit heaters, boilers, and other equipment. Model 143-80-1 is a standard regulator, Model 143-80-2 includes an internal relief valve, and Model 143-80-6 offers low pressure cut-off.

1. Remove the shipping plugs from both the regulator inlet and outlet connections.
2. Make certain that the inside of the piping and the regulator inlet and outlet connections are free of dirt, pipe dope and other debris.
3. Use pipe joint material only on the male threads of the pipe being connected to the regulator. Do not use pipe joint material on the female threads of the regulator.
4. Install the regulator in the piping. Make certain that the gas flow through the regulator is in the direction as indicated by the arrow on the regulator body.

The regulators may be installed in any position: right side up, upside down, vertical piping, diagonal piping, etc.,. If required, the diaphragm case may be rotated 360° in any angle increment. To rotate the 143-80 diaphragm case, loosen the coupling nut (12) and reposition the diaphragm case to the desired position. Re-tighten the coupling nut to 35-50 ft.-lbs. (12) to reseal the regulator. Ensure proper seal and verify no leaks by using a soap and water solution or other utility-approved method.

The diaphragm case vent (11) should be positioned to minimize the chances of moisture collecting on the vent side of the diaphragm.

The diaphragm case vent must be positioned to protect against flooding, rain, ice formation, traffic, tampering, etc. The vent must be protected against nest building animals, bees, insects, etc. to prevent vent blockage and minimize the chances for foreign material from collecting

5. Turn the gas on very slowly.
6. If installing model 143-80-6 Low Pressure Cutoff (LPCO), remove cap (1) and pull up pin located inside spring housing to deactivate LPCO device and initiate flow through the regulator.
7. Make certain that all connections are tight. Ensure proper seal and verify no leaks by using a soap and water solution or other utility-approved method.
8. If needed, adjust outlet pressure (set point) by removing cap (1) and turning adjustment spring button (2). Turn clockwise to increase and counter-clockwise to decrease outlet pressure. Only adjust when gas is flowing through regulator. Be sure to reinstall cap.

# Model 143-80 Service Regulator

## Installation and Maintenance Instructions



9. The vent connection is an escape path for the regulated gas. Depending upon the type of gas, it could be flammable as with natural gas and propane. Therefore, the vent connection needs to be located and/or piped so that potential discharge occurs in a safe area away from buildings, open flames, collection areas, arcing devices, etc.

Regulators that are installed indoors or in a non-vented area must be vented to the outside. Run vent piping from the regulator vent connection to a non-hazardous location on the outside away from any potential sources of ignition. For regulators equipped with internal relief valves (IRV), The vent piping must be vent connection size or larger and its length be as short and direct as possible to a safe area. This is to assure the venting of the internal relief valve discharge to the atmosphere without excessive pressure increase in the regulator and downstream piping.

The outlet of the vent piping must allow for free and unobstructed passage of air and gas and must be protected against the potentials listed in instructions #4, #8 and #9.

10. For outdoor installations, it is recommended that the regulator be installed so that the regulator vent faces downward to avoid the potential for water and other foreign matter entering the regulator and interfering with the proper operation of the regulator.

## Servicing

1. To access valve (7), orifice (6), or diaphragm assembly (8), first remove spring compression by unscrewing the spring cap (1) and spring adjustment ferrule (2). Remove spring (3) from regulator.
2. For access to the valve (7) and orifice (6), completely loosen the coupling nut (12) and remove diaphragm case assembly from body (5).
3. To replace valve pad (7), simply pull off of valve stem (9) and replace with new pad.
4. To replace orifice (6), unscrew from body using a 1" hex socket wrench "thin-wall" type. Apply sealant on threads of orifice when installing replacement orifice. The replacement orifice must be installed at 50-60 ft-lbs. of torque.
5. To replace diaphragm assembly, remove flange screws (10) and disassemble diaphragm assembly. Make certain all parts are reassembled in their correct order and all threads and joints are tightened evenly and firmly.
6. Before reassembling body to diaphragm case, make certain that the O-ring is in position. Ensure proper seal and verify no leaks by using a soap and water solution or other utility approved method.

## Caution



It is the user's responsibility to assure that all regulator vents and/or vent lines exhaust to a non-hazardous location away from ANY POTENTIAL sources of ignition. Where vent lines are used, it is the user's responsibility to assure that each regulator is individually vented and that common vent lines ARE NOT used.

## Caution



Regulators are pressure control devices with numerous moving parts subject to wear that is independent upon particular operating conditions. To assure continuous satisfactory operation, a periodic inspection schedule must be adhered with the frequency of inspection determined by the severity of service and applicable laws and regulations.

## Over Pressurization Protection

Protection must be provided for the downstream piping system and the regulator's low pressure chambers to assure against the potential for over-pressurization due to a regulator malfunction or a failure of the regulator to lock up. The allowable over-pressurization is the lowest of the maximum pressures permitted by federal codes, state codes, or other applicable standards. The methods of providing overpressure protection could be a relief valve, a monitor regulator, a shut-off valve or similar device.

## Buried Service

The Model 143-80 regulator is not recommended for buried service.

## Temperature Limits

The Model 143-80 regulator can be used for the flowing temperature of -20°F to 150°F (-28.9°C to 65.5°C).

## Maximum Emergency Pressures

The maximum pressure to which the regulator inlet may be subjected under abnormal conditions, without causing damage to the regulator, is the stated Maximum Inlet Pressure + 50 psi. The maximum pressure to which the regulators case may be subjected under abnormal conditions without causing damage to the internal parts is: Set point plus 3 psi. If the outlet pressure exceeds this pressure, the regulator must be removed from service and carefully inspected. Damaged or otherwise unsatisfactory parts must be replaced before returning the regulator to service. The maximum outlet pressure that can be safely contained in the diaphragm case is 10 psi (safely contained means no leakage as well as no bursting.)